

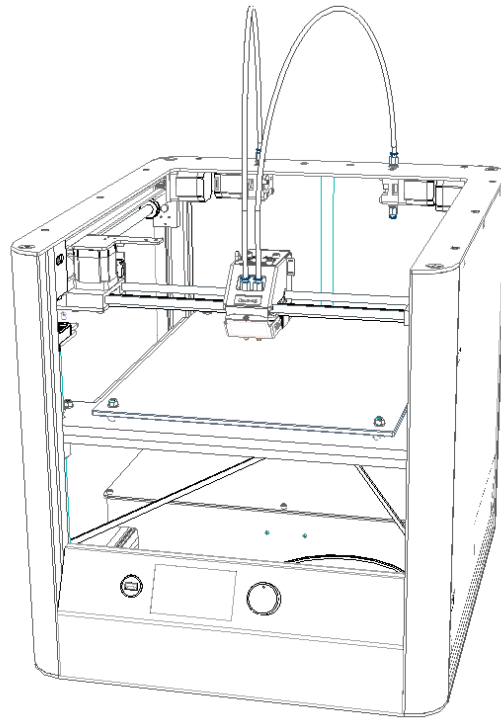

Leapfrog Creatr HS

DATASHEET

V01-04



Contents

1. Overview.....	2
2. Technical specifications	3
3. Non-disclosure	3



1. Overview

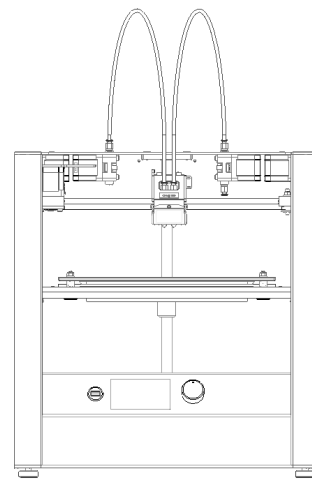
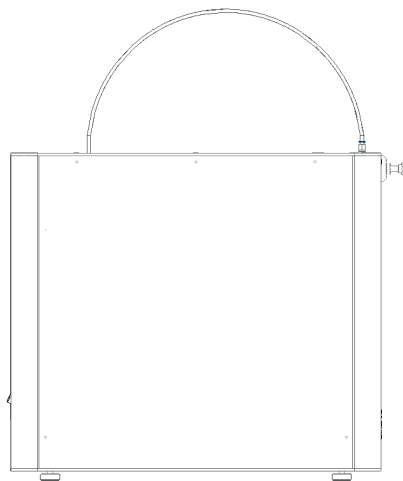
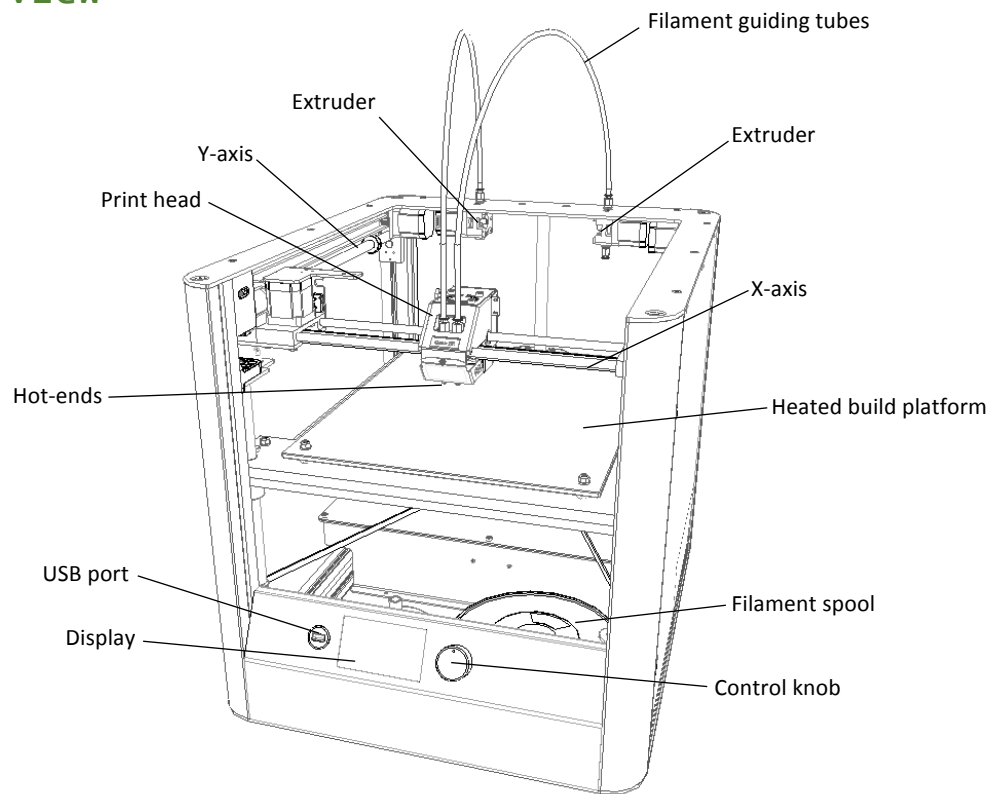

2. Technical specifications

Specification	Metric	Imperial		
Physical dimensions (DWH)*	633 x 486 x 523 mm	24.9 x 19.1 x 20.6 inch		
Input power**	85-133VAC / 170-264VAC			
Input frequency	47 - 63 Hz			
Power consumption	4 Amp. @230V / 6.4 Amp. @ 115V			
Build size single extruder (DWH)	280 x 270 x 180 mm	11.0 x 10.6 x 7.1 inch		
Build size dual extruder (DWH)	280 x 240 x 180 mm	11.0 x 9.4 x 7.1 inch		
Build volume	13.6 L.	3.0 Gal.		
Heated bed	Max. 90°C	Max. 194°F		
Hot end	Max. 275°C	Max. 527°F		
Number of extruders	2			
Extruder size	0.35 mm	0.014 inch		
Filament size	1.75 mm	0.069 inch		
Layer thickness	0.02 – 0.35 mm	0.00079 – 0.014 inch		
Max. print speed (DW)	18000 mm/min.	300 mm/sec.	708.66 inch/min.	11.8 inch/sec.
Max. travel speed (DW)	24000 mm/min.	400 mm/sec.	944.88 inch/min.	15.8 inch/sec.
Stepper motors	1.8° Step angle with 1/16 micro stepping			
Positioning accuracy (DW)	0.0169 mm	0.00067 inch		
Positioning accuracy (H)	0.02 mm	0.00079 inch		
Body/frame construction	Aluminium extrusion profiles			
Printbed Z-levelling	4-knob hand levelling			
Internal OS	Linux			
USB standalone format	.gcode format			
USB accepted drive storage size	Not limited			
USB connection to computer	Virtual COM port			
Supported computer OS	Windows 98, XP SP3 32-bit, SP2 64-bit, Vista, 2000, Server Editions OS X Mavericks 10.9 or later			

*DWH: Depth, Width, Height. Coordinate system reference Y, X, Z

**Power input is set by Leapfrog, customers cannot change power input between 230/110V

3. Non-disclosure

This document, and parts of this document including images, drawings and schematics, remain property of Leapfrog BV and may not be distributed, copied digitally, photocopied, photographed or copied in any other way. All information described in this document is classified and may not be discussed or negotiated with third parties without express written permission of Leapfrog BV.

The recipient(s) of this document is (are) aware of this confidentiality and agree to the above.

Violating this non-disclosure may result in penalties decided by Dutch law and/or international corporate law.